

Manitex



CM190

19-ton (17 mt) TELESCOPIC CRANE
PRELIMINARY PRODUCT GUIDE

PRELIMINARY CONTENTS ////////////////////////////////////

- Crane Features 4
- Boom Diagram 5
- Load Chart: Main Boom & Jib 6
- LMI Codes 7
- Reeving Diagram..... 7
- Crane Dimensions 8
- Chassis Data 8
- Crane Weights 8
- Outrigger Extension..... 9
- Area of Operation 9
- Technical Descriptions 10-11
- Options 11

Effective Date: September 1, 2013

This document is non-contractual. This document is supplied for reference use only. We are constantly making improvements to our products and reserve the right that specification, equipment, and prices are all subject to change without notice or obligation.

The photographs, and /or images in this document are for illustrative purposes only and may include optional equipment and accessories and may not include all standard equipment.

Refer to the appropriate Operator's Manual and Load Charts for instructions on the proper use of this equipment to determine allowable crane lifting capacities, assembly and operating procedures.

Failure to follow the appropriate operator's manual or load chart(s) when using our equipment or to otherwise act irresponsibly may result in serious injury or death.

The only warranty applicable to our equipment is the standard written warranty applicable to the particular product and sale. Manitex makes no other warranty, expressed or implied.



















Products and services listed may be trademarks, service marks or trade-names of Manitex International and /or its subsidiaries in the USA and other countries.

















All rights are reserved. Manitex® is a registered trademark of Manitex International, Inc. in the USA and many other countries.

Copyright 2013 Manitex Inc. Manitex Inc, Georgetown Texas, 78626



KEY

	Operator aids
	Cab
	Heating / Air conditioning
	Controls
	Hoist speed
	1 - Main hoist 2 - Auxiliary winch 3 - Recovery winch
	Rope length
	Rope - standard/optional
	Rope diameter
	Permissible line pull
	Maximum line pull
	Slewing / Allowable slewing range
	Slewing gears
	Slewing brake
	Outriggers / Lifting on outriggers
	2-Person man basket
	Counterweight
	Radio remote control

	Hook block
	Distance from hook to head sheave pin
	Hook and ball
	Hydraulics
	Boom elevation angle
	Max. boom length with extension
	Boom with extension retracted
	Boom angle
	Telescoping mode
	Working radius
	Boom length
	Hydraulic actuated boom
	Full power mechanical synchronized
	Boom head / Hook block dimension
	Main boom with auxiliary head
	Tip height

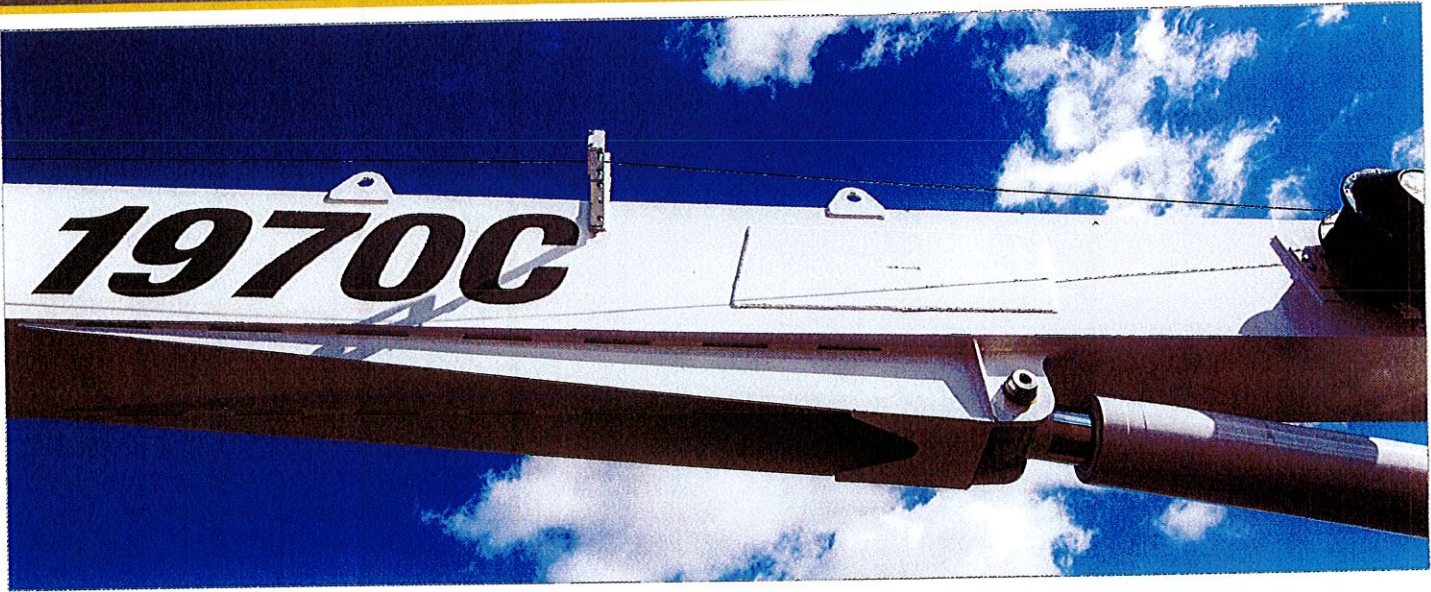

THE CM190 TELESCOPIC CRANE

Maximize Rental Use and Value

The CM190 telescopic crane strikes the perfect balance between the three things customers tell us they care about most in a rental crane: features, cost and ease of use. It's one of the highest-capacity cranes available on a 4x2 chassis, yet it's competitively priced and packed with standard features designed to save time and money.

- Change line speed on the fly and minimize rope stacking with its 2-speed planetary hoist with grooved drum and negative draft flange.
- Minimize maintenance costs with replaceable, self-lubricating boom slider pads.
- Get active and immediate feedback on load with the integrated load-moment indicator system.

Other features include:

- 19-ton capacity @ 5 ft. radius
- 70 ft. 3-section proportional boom
- 80.8 ft. max boom tip height
- Optional 24 ft. fixed jib
- Optional 24 ft./41 ft. telescopic jib
- Wired anti-two block with lockout ATB
- Removable boom rest

USER-FRIENDLY CONTROLS

Dual operator stations are equipped with engine start/stop, foot throttle, signal horn, boom angle indicator, load chart and range diagram.

OUTRIGGER DEPLOYMENT

An audible alarm sounds as outriggers are being deployed, and indicator lights verify when they are fully extended.

LOAD MOMENT INDICATOR

The load-moment indicator sounds a warning or shuts down the machine when lift limitations are about to be exceeded.

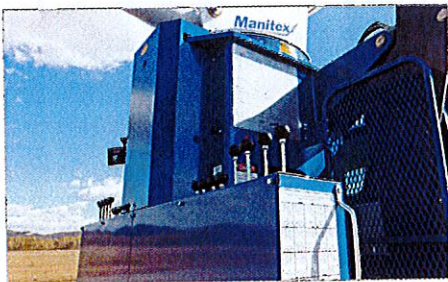

INCREASE PROFITABILITY

The versatile CM190, designed to be used with a commercial carrier, helps both owners and operators make the most of their investment.

- Travel to and between jobs at highway speed.
- Ride in comfort with a carrier suspension designed for highway driving.
- Get repairs done quickly and by qualified technicians at commercial truck centers.



BOOM DIAGRAM

Imperial & Metric Units

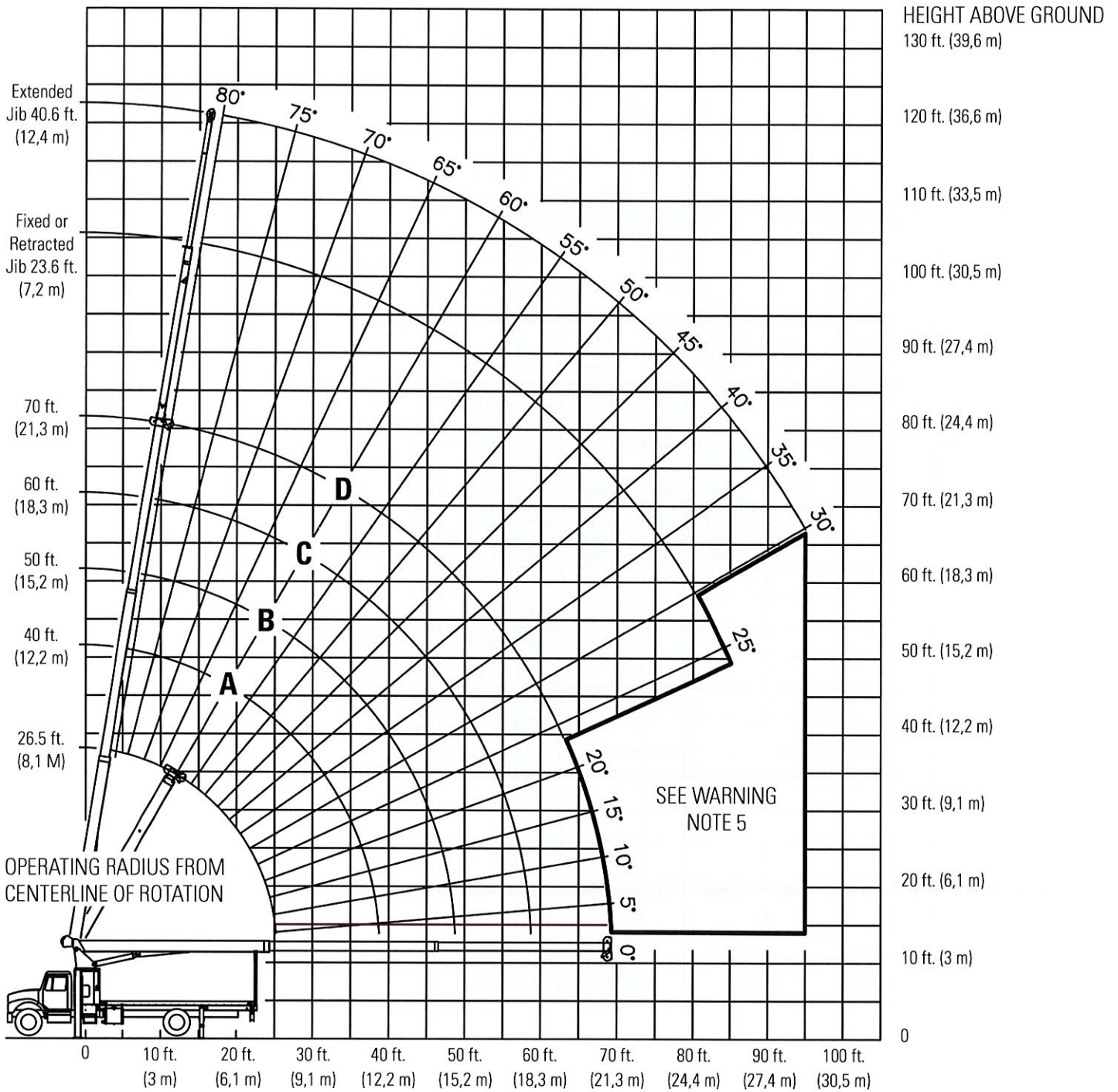

Data published herein is intended as a guide only. Crane operations is subject to machine specific load charts and information.

LOAD CHART: Main Boom and Jib

Lifting Capacities 3-section Boom 26.5 ft. - 70 ft.
Jib 23.6 ft. - 40.6 ft.

 20.8 ft. (100%)

 372° Non-continuous

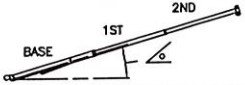
Load Ratings in (lbs.) with Outriggers and Stabilizers Extended											Jib Load Ratings in (lbs.) with Outriggers and Stabilizers Extended							
LMI Code #1											LMI Code #2							
Loaded Boom Angle (ft.)	Loaded Boom Angle (°)	Boom Length & Marker									Fixed Jib		Telescopic Jib					
			A (lbs.)		B (lbs.)		C (lbs.)		D (lbs.)		LMI Code #3	LMI Code #4	LMI Code #3	LMI Code #4	LMI Code #3	LMI Code #4		
			40 ft.	50 ft.	60 ft.	70 ft.					Loaded Boom Angle (ft.)	Jib Length for All Boom Lengths See Warning Note 4	Loaded Boom Angle (ft.)	Jib Length for All Boom Lengths See Warning Note 4	Loaded Boom Angle (ft.)	Jib Length for All Boom Lengths See Warning Note 4		
5	79	38,000																
8	73	27,010	79	24,000														
10	68	22,330	76	21,100	80	18,000					10							
12	63	18,410	73	18,230	77	16,320	80	13,420			12							
15	55	14,420	69	14,600	74	13,940	77	11,900	80	9,400	15							
20	40	10,350	61	10,540	68	10,600	72	9,810	76	8,180	20	80	4,400	80	4,200			
25	12	7,830	52	8,070	61	8,130	67	8,170	71	7,000	25	78	4,200	78	4,000	80	3,000	
30			41	6,400	54	6,470	62	6,510	67	6,050	30	75	4,000	75	3,800	78	2,660	
35			28	5,160	47	5,240	56	5,280	62	5,280	35	71	3,600	71	3,380	75	2,380	
40					37	4,200	50	4,260	58	4,300	40	68	3,220	68	3,010	72	2,150	
45					25	3,360	43	3,420	52	3,460	45	65	2,880	65	2,650	69	1,940	
50							35	2,790	47	2,820	50	61	2,580	61	2,340	66	1,770	
55							24	2,290	40	2,330	55	57	2,310	57	2,060	63	1,620	
60									33	1,930	60	53	2,020	53	1,790	60	1,490	
65									23	1,600	65	49	1,690	49	1,460	57	1,380	
70											70	45	1,410	45	1,180	54	1,280	
75											75	40	1,180	40	950	51	1,190	
80											80	34	980	34	750	47	1,030	
85											85	27	810	27	570	43	850	
90											90					39	700	
95											95					34	560	
	0	6,650	0	3,820	0	2,700	0	1,960	0	1,370								
		350 lbs.		240 lbs.		190 lbs.		160 lbs.		140 lbs.								Deductions for stowed fixed jib
		530 lbs.		350 lbs.		280 lbs.		240 lbs.		200 lbs.								Deductions for stowed telescopic jib

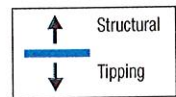

NOTES:

- All loads rated at 360° pick
- Loads based on crane on outriggers
- All "on outriggers" loads are based on 85% tipping
- Loads above heavy line are based on structural rating
- Loads below heavy line are based on tipping rating





Data published herein is intended as a guide only. Crane operations is subject to machine specific load charts and information.

LMI OPERATING CODES

Code	Crane Configuration	Outrigger Configuration	Area of Operation
#1	Main Boom	Fully Extended	372° Non-continuous
#2	Fixed Jib	Fully Extended	372° Non-continuous
#3	Telescopic Jib - Retracted	Fully Extended	372° Non-continuous
#4	Telescopic Jib - Extended	Fully Extended	372° Non-continuous
#5	Personnel lifting platform on main boom	Fully Extended	372° Non-continuous
#6	Personnel lifting platform on fixed jib	Fully Extended	372° Non-continuous
#7	Personnel lifting platform on tele. jib - retracted	Fully Extended	372° Non-continuous

WARNING: Lifting personnel from extended jib is not approved.

REEVING DIAGRAM

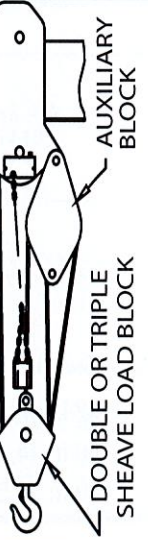
ALLOWABLE LINE PULL					WARNING
1 PART LINE	2 PART LINE	3 PART LINE	4 PART LINE	5 PART LINE	
					<p>ANTI-TWO-BLOCK SYSTEM MUST BE IN GOOD OPERATING CONDITION BEFORE OPERATING CRANE. REFER TO OWNER'S MANUAL.</p> <p>KEEP AT LEAST 3 WRAPS OF LOAD LINE ON DRUM AT ALL TIMES.</p>
8500 LBS	17000 LBS	25500 LBS	34000 LBS	38000 LBS	
7700 LBS	15400 LBS	23100 LBS	30800 LBS	38000 LBS	
					<p>9/16" - 6X25 IWRC (3.5:1 S.F.) 29750 LBS. BREAKING STRENGTH</p> <p>9/16" ROT RESISTANT (5.0:1 S.F.) 38800 LBS. BREAKING STRENGTH</p>

CRANE DIMENSIONS

Imperial & Metric Units

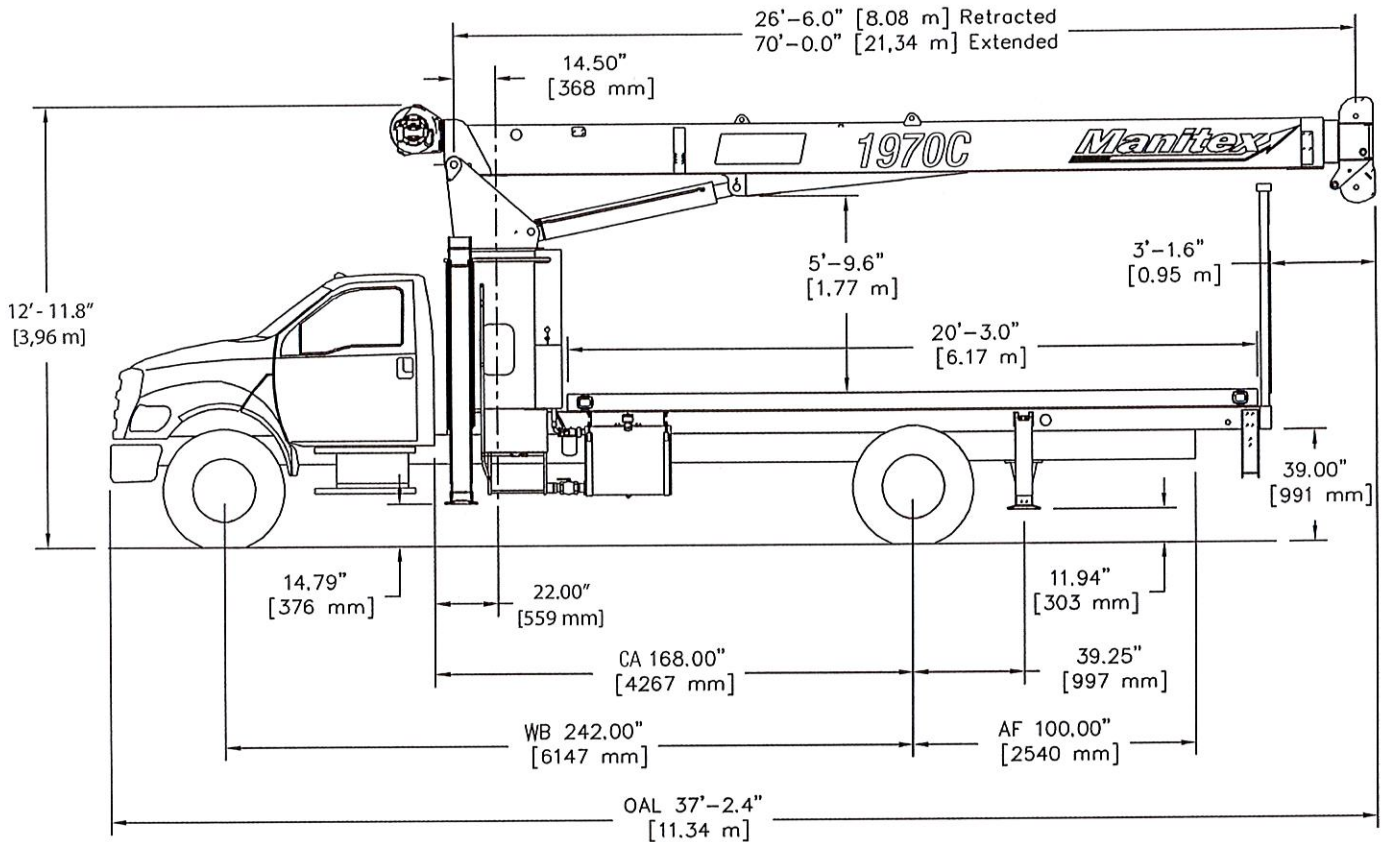

CHASSIS DATA

Wheelbase (WB):	242 in. (6,147 mm)	Minimum truck axle weight - front*	6,000 lbs. (2,722 kg)
Cab to axle (CA):	168 in. (4,267 mm)	Minimum truck axle weight - rear*	4,000 lbs. (1,814 kg)
After frame (AF):	100 in. (2,540 mm)	Nominal frame W:	34 - 35 in. (864 - 889 mm)
Frame section modulus at 180°/360° rotation (min.):	15.9 in. ³ - 110,000 psi (758,422 kPa)	Front axle gross weight rating:	12,000 lbs. (5,443 kg)
		Rear axle gross weight rating:	21,000 lbs. (9,525 kg)

CRANE WEIGHTS

Basic crane weight:	14,625 lbs. (6,634 kg)
Fixed jib 23.6 ft. (7,2 m):	532 lbs. (241 kg)
Telescoping jib: 23.6 ft. (7,2 m) to 40.6 ft. (12,4 m):	823 lbs. (373 kg)
Flatbed 20 ft. (6,1 m):	1,720 lbs. (780 kg)

* Flatbed weight not included in crane weight.

Notes: Additional axles required for federal bridge legal configuration - consult Manitex.
The addition of a front stabilizer is highly recommended and may be required on some installations - consult Manitex.

Data published herein is intended as a guide only. Crane operations is subject to machine specific load charts and information.

OUTRIGGER EXTENSION

Imperial & Metric Units

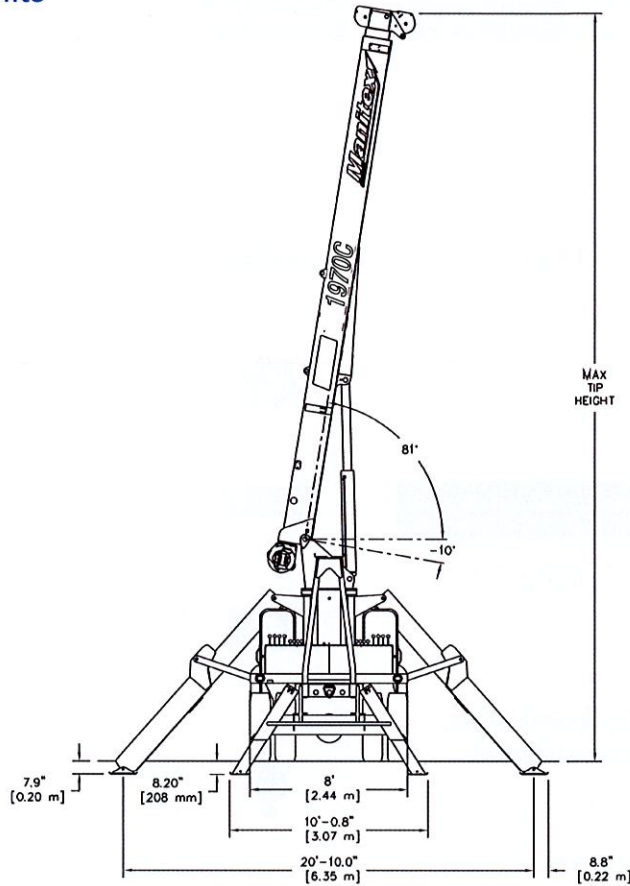

AREA OF OPERATION

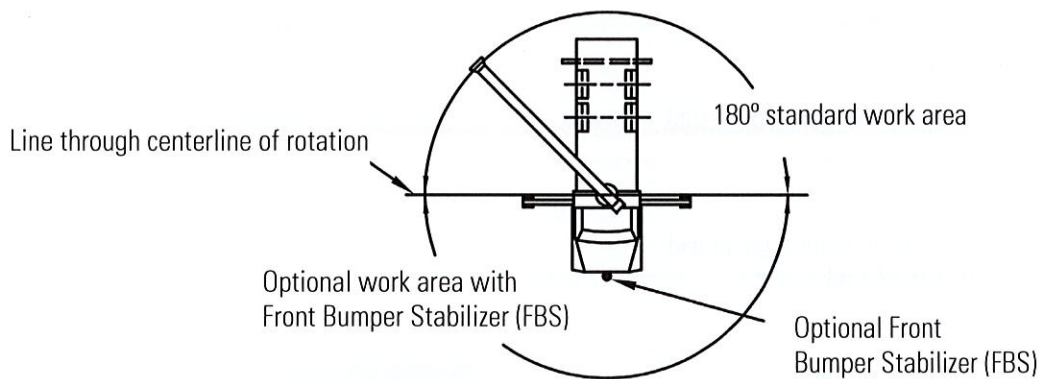

Deductions from rated loads for load handling devices supplied by Manitex

Overhaul ball

Load blocks

Hose reel

Swing-around jib

See overhaul ball mfr. nameplate

See block mfr. nameplate

160 lbs. (73 kg)

See load chart

WARNING: Lifting off the main boom point while the jib is erected is not intended or approved.

Data published herein is intended as a guide only. Crane operations is subject to machine specific load charts and information.

TECHNICAL DESCRIPTIONS

Boom



Boom length: 3-section 70 ft. (21,3 m)
proportional boom
3-sheave quick reeve boom point



Boom max. tip height: 80.8 ft. (24,6 m)
Boom min. tip height: 37.7 ft. (11,5 m)



Boom angle (min/max): -10° / 80°

Rotation



Oversized diameter ball bearing swing circle
with external gear



Slewing brake: Wet, multi-disc internal brake,
spring applied, hydraulic pressure released



Boom rotation: 372° non-continuous
Slewing speed: 1.5 - 2 rpm. (nominal)

Outriggers



Outriggers: A-frame

Front Spread

- A-frame, to outer edge of pad:
20.8 ft. (6,4 m)

Rear Spread

- A-frame, to outer edge of pad:
10.1 ft. (3,1 m)

Stowed

- A-frame, to outer edge of pad:
8 ft. (2,4 m)

Outrigger motion alarm

Hoist, Rope and Hook



Maximum theoretical line speed:
300 fpm (91 mpm)



Maximum theoretical bottom-layer line pull:
11,500 lbs. (5,216 kg)



Main winch cable diameter: 9/16 in.
(14,3 mm) 6 x 25 EIPS IWRC



Line length: 300 ft. (91,4 m)



Main winch: Bent axis 2-speed hydraulic
motor (activated electrically)



Load ball: 5T (4,5 mt) capacity hook with
heavy-duty swivel and weight is provided for
single line operation.

Hydraulics



6-8 bolt direct mounted PTO and SAE B or
output or SAE BB output
3-section gear pump, SAE BB input (standard)
Hydraulic reservoir capacity: 70 gal. (265 L)
Pump sections @ 2000 rpm with 100 psi

- Shaft end pump: 32.4 gpm (123 lpm)
- Center pump: 20.6 gpm (78 lpm)
- Cover end pump: 10 gpm (38 lpm)

Operator aids



LMI with crane function cut-offs for
overload protection

Graphical display

Anti-two block system - Cable externally routed



TECHNICAL DESCRIPTIONS

Control System



Dual operating stations are equipped with four single-lever crane controls arranged in accordance with ANSI B30.5 standards.

Fully proportional control valves

Each station includes:

- Individual control levers for each outrigger and stabilizer
- Engine start and stop
- Electronic foot throttle
- Signal horn
- Boom angle indicator
- Beverage holder
- Load chart with range diagram and mount for removable LMI display

Electrical System

State-of-the-art, weather-resistant components throughout

Hermetically sealed enclosure includes power in relays and circuit status LEDs

Mounting System

Pedestal sub-frame and stabilizers are mounted to chassis by threaded rods and clamp plates

Sub-frame: Torsion resistant, rigid 4-plate design mounted under crane full length of truck frame

Rear under-ride protection: Standard on factory mounted cranes.

Boom rest: Heavy-duty fabrication, easily removed for unencumbered loading and unloading of crane deck.

Options

Tool Boxes & Bulkhead

24 in. L x 20 in. W x 18 in. H - Steel
(610 mm L x 508 mm W x 457 mm H)

48 in. L x 24 in. W x 24 in. H - Aluminum
(1219 mm L x 610 mm W x 610 mm H)

Bulkhead: 24 in. (610 mm)

Options

Jib



1-section fixed jib 23.6 ft. (7,2 m)

2-section telescopic jib
23.6 ft (7,2 m) - 40.6 ft. (12,4 m)



Max. boom tip height with extension:
121.2 ft. (36,9 m) from ground

Max. boom tip height with extension retracted:
104.5 ft. (31,9 m) from ground

Hoist, Rope and Hook



Load block: 1-sheave

Hydraulics



3-section vane pump, SAE B input

Hydraulic oil cooler

Hose reel - boom mounted

FBS - Front Bumper Stabilizer

2-Person Baskets



2-person man basket - Aluminum or steel - consult Manitex

- Non-rotating (600 lbs. cap.)
- Rotating (1,000 lbs. cap.) - main boom only

Operator Aids



4-Function radio remote crane control system

Bed Options

20 ft. (6,1 m) Wood or steel

20 ft. (6,1 m) Steel heavy hauler

In order to ensure continuous improvement, Manitex reserves the right to change design and specifications without notice.

Manitex



CM190

19-ton (17 mt) TELESCOPIC CRANE
PRELIMINARY PRODUCT GUIDE

UPTime

UPTime is the Manitex commitment to complete support of thousands of units working every day.

MANITEX

3000 South Austin Avenue
Georgetown, Texas 78626

1-877-314-3390 | www.Manitex.com

MTX-CM190-PC-EN-V1-1013